



Complete, plug-and-play  
Bluetooth 1.2 solutions in  
a single package

## NXP Bluetooth 1.2 SiPs BGB203, BGB204

These complete Bluetooth 1.2 solutions, designed for a range of mobile applications, provide complete, plug-and-play operation in a single package as small as 49 mm<sup>2</sup>. They also support coexistence with 802.11 WLAN.

### Key features

- ▶ Complete, fully tested Bluetooth 1.2 SiP
  - Supports Bluetooth 1.2 specification, including eSCO
  - Low total cost of ownership
- ▶ Ultra-small HVQFN package
  - BGB203 (Flash): 7 x 8 x 1.3 mm
  - BGB204 (ROM): 7 x 7 x 1.0 mm (footprint compatible with BGB203)
- ▶ Highly integrated solution
  - No RF-critical layout or external components
  - Integrated RF filters, balun, switches
  - ARM7 processor
  - Embedded 268k Flash (BGB203) or ROM (BGB204)
  - High-performance Bluetooth 1.2 core
  - System interfaces (UART, USB, I<sup>2</sup>C, PCM, JTAG)
  - Proven N-ZIF RF transceiver
- ▶ High-performance radio for excellent range and audio quality
- ▶ Coexists with 802.11 WLAN

### Applications

- ▶ Smartphones and cellular phones
- ▶ Headsets and car kits
- ▶ PDAs and handheld computing devices
- ▶ Computer peripherals (keyboards, mice, printers, etc.)
- ▶ Portable media players

The BGB203 and BGB204 are second-generation System-in-a-Package (SiP) solutions for Bluetooth 1.2 wireless connectivity. They provide complete, plug-and-play Bluetooth 1.2 operation in a low-cost package as small as 49 mm<sup>2</sup>. Optimized for short-range hosted and embedded applications, they reduce board space, lower overall cost, and speed time-to-market for a wide range of mobile applications, including mobile phones, headsets, car kits, PDAs, and computer peripherals.

The SiP format, with its complete system functionality, delivers quicker design cycles, lower risk, simplified manufacturing, and a reduced bill of materials. The single-package format also simplifies assembly and testing, and reduces yield losses.

### Industry-leading integration and size

Advanced process technologies and packaging techniques combine to optimize cost, size, and performance. The result is a Bluetooth solution that requires no RF-critical layout or external components.

The baseband, which is manufactured in a cost-effective, low-power CMOS technology, includes an ARM7 processor, 268k of embedded Flash (BGB203) or ROM (BGB204) memory, an industry-leading Bluetooth 1.2 core, and a variety of interfaces, including UART, USB, I<sup>2</sup>C, PCM, and JTAG.

The radio subsystem, manufactured in an advanced BiCMOS technology that enhances performance, is based on a Near-Zero IF (N-ZIF) radio transceiver. Passive integration technologies add a loop filter, an antenna filter that provides enhanced out-of-band blocking performance, a Tx/Rx switch, Tx and Rx baluns, the VCO resonator, and basic supply decoupling.

The entire system is housed in an HVQFN package that measures only 7 x 8 x 1.3 mm (BGB203) or 7 x 7 x 1.0 (BGB204). Only an external clock source and an antenna are required for operation.

### Embedded Flash/ROM

The BGB203 uses a 0.15- $\mu$ m CMOS process and embeds 268k of Flash memory. The BGB204 uses a state-of-the-art 0.09- $\mu$ m CMOS process and embeds 268k of ROM. For headset and car kit applications, the BGB203 and BGB204 can be combined with the PCF87757 Blueberry™ Voice, a small (3 x 3 mm<sup>2</sup>) 1.8V voiceband codec. The on-board ROM and I<sup>2</sup>C PROM, associated with a patch mechanism, make it easy to upgrade new headset or car kit software to the BGB204. NXP provides an optimized lower-level Bluetooth stack, so designers can modify the upper-level stack and port it to the Flash memory of the BGB203.

For easy upgradeability, the BGB204 is footprint-compatible with the BGB203. This provides a flexible path from Flash to ROM, optimizing cost and significantly reducing project risk.

### High-performance radio

The BGB203 and BGB204 use a robust, high-performance radio that provides excellent range along with high-quality data and voice links. The radio exceeds the Bluetooth blocking spec by 20 dB in the cellular frequency bands. It offers a typical output power of +5 dBm at the antenna and offers industry-leading sensitivity (-85 dBm) at the antenna port.

### 802.11 coexistence

The BGB203 and BGB204 are designed to support collaborative coexistence with IEEE 802.11 Wireless LAN (WLAN) systems. A dedicated software and hardware interface implements Adaptive Frequency Hopping (AFH) and Packet Traffic Arbitration (PTA), with voice priority between the BGB20x and the WLAN system. An auto shutdown feature ensures that Bluetooth voice takes priority over other signals, and there is special support for burst and fragmented frames.

Bluetooth 1.2 features enhance coexistence further. The BGB203 and BGB204 offer independent AFH capability, support extended Synchronous Connection-oriented link (eSCO), which provides higher quality voice links, and support Fast Connect, which provides faster connection times between Bluetooth devices.

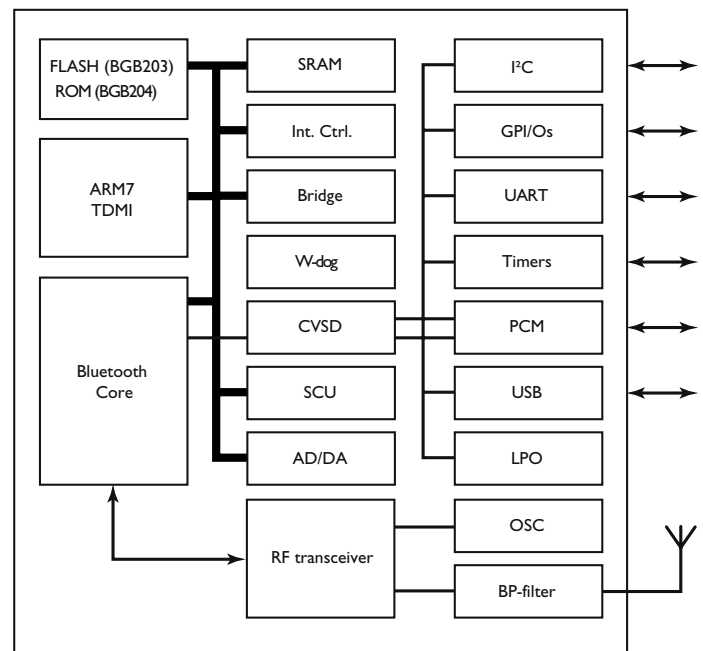

BGB210 functional block diagram

| Part No. | Description       | Memory | Process           | Size           |
|----------|-------------------|--------|-------------------|----------------|
| BGB203   | Bluetooth 1.2 SiP | FLASH  | 0.15 $\mu$ m CMOS | 7 x 8 x 1.3 mm |
| BGB204   | Bluetooth 1.2 SiP | ROM    | 0.09 $\mu$ m CMOS | 7 x 7 x 1.0 mm |